

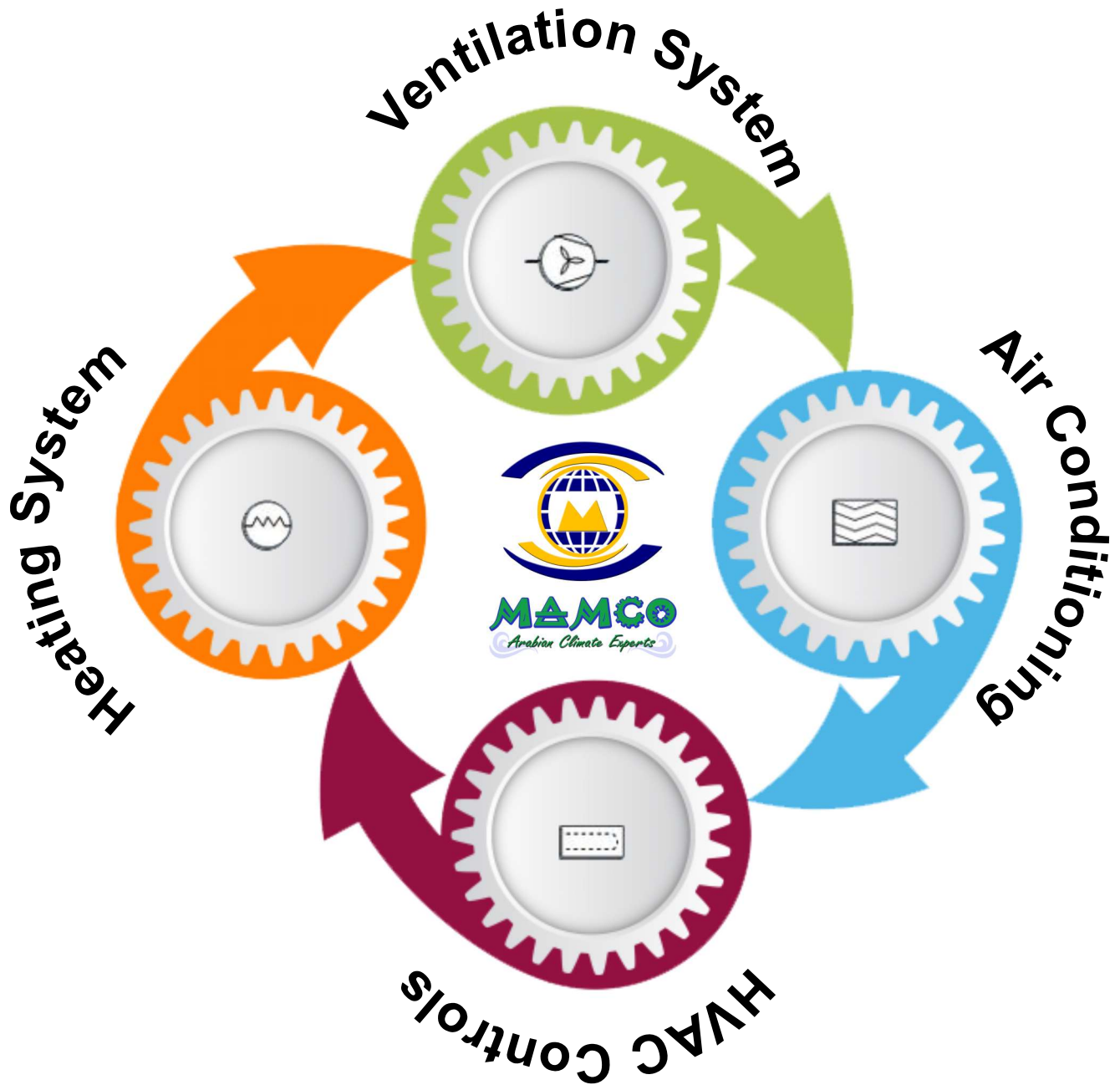

**MAMCO**  
*Arabian Climate Experts*



**PRE QUALIFICATION**



# GREETINGS

You are always welcome,  
Mohammed ali al Musallam Gen.Con.Co.,  
Focused on providing better quality of service by  
making transparent business with client and high  
compony brand value.

We believe that business confidence is the best  
reward for the customers.

**Thank you,**

Our customers, for your continued trust and support.  
We will make more effort to have the global  
competitiveness and provide the best technical skills,  
services & always challenge ourselves to be a  
leading HVAC company in KSA

**President & Chairman of MAMCO**  
**Mohammed Ali Musallam**





**MAMCO**  
*Arabian Climate Experts*



**ABOUT US...**



Mohammed Ali Al Musallam Gen. Con, is a professional HVAC (Heating, Ventilation and Air Conditioning) contractor with a proven successful experience and record in this field with good trouble shoot finders.

Firm quality plan is always to adhere to provide the clients with the best quality products works and services in accordance with the top national S international quality Control system standards a3 per SASO, ASHRAE & SMACNA

Quality control program covers the regular and specific inspection and test plans during all stages of HVAC works, including manufacturing if specified), fabrication, installation, commissioning and operation with all associated inspections, balancing and testing.



ASHRAE  
Associate  
Society  
Alliance





**MAMCO**  
*Arabian Climate Experts*

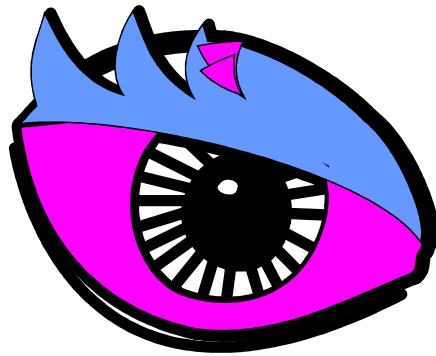
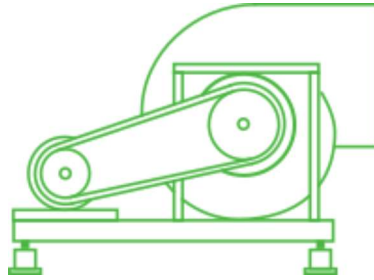

**OUR VISION**

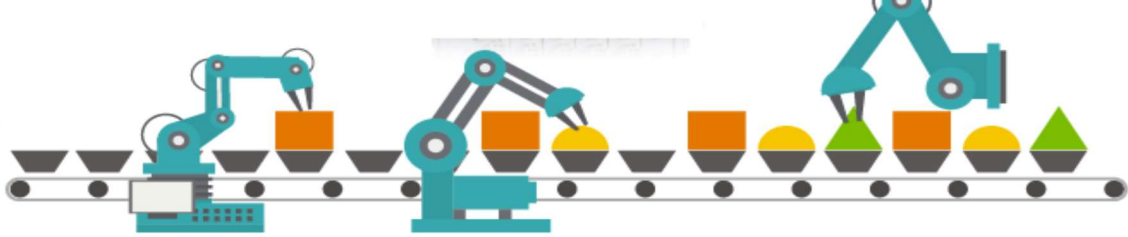

**Mohammed Ali Al Musallam Gen. Con. Always Looking Forward To Become The Leading Partner in Providing The Services Of Ventilation And Air—condition as well as Ma Inte Nance Services In the Kingdom and in Middle East through Our Performance Quality, Our Well Knowledge And Our Distinguished Team.**

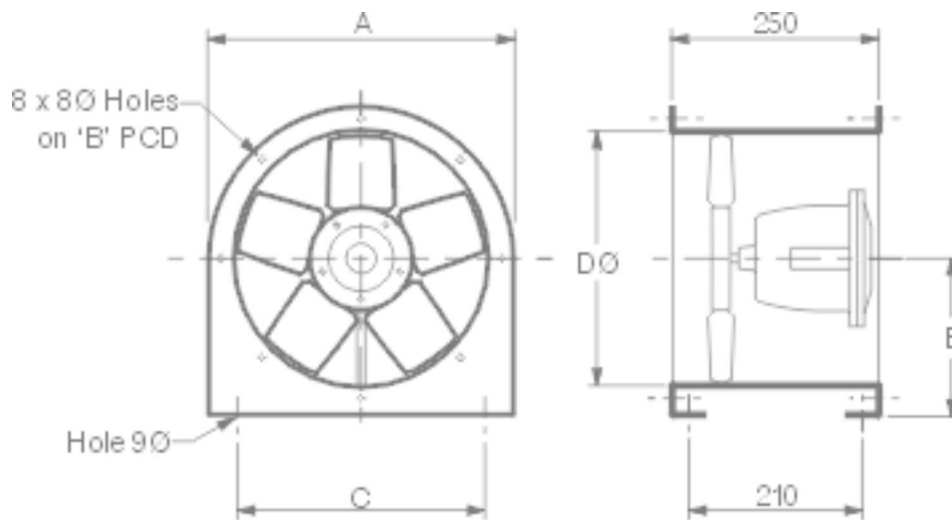



# Value Statement,

Increasing the life of HVAC System at low cost. Prevent your HVAC System from Arabian sandstorm. Feel to be in safe hands of Arabian climate experts. In emergency MAMCO will work in light velocity.

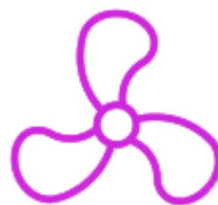
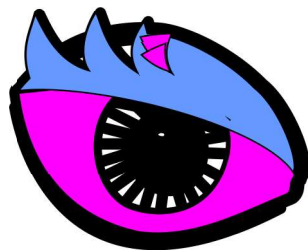





**MAMCO**  
*Arabian Climate Experts*



**OUR MISSION**

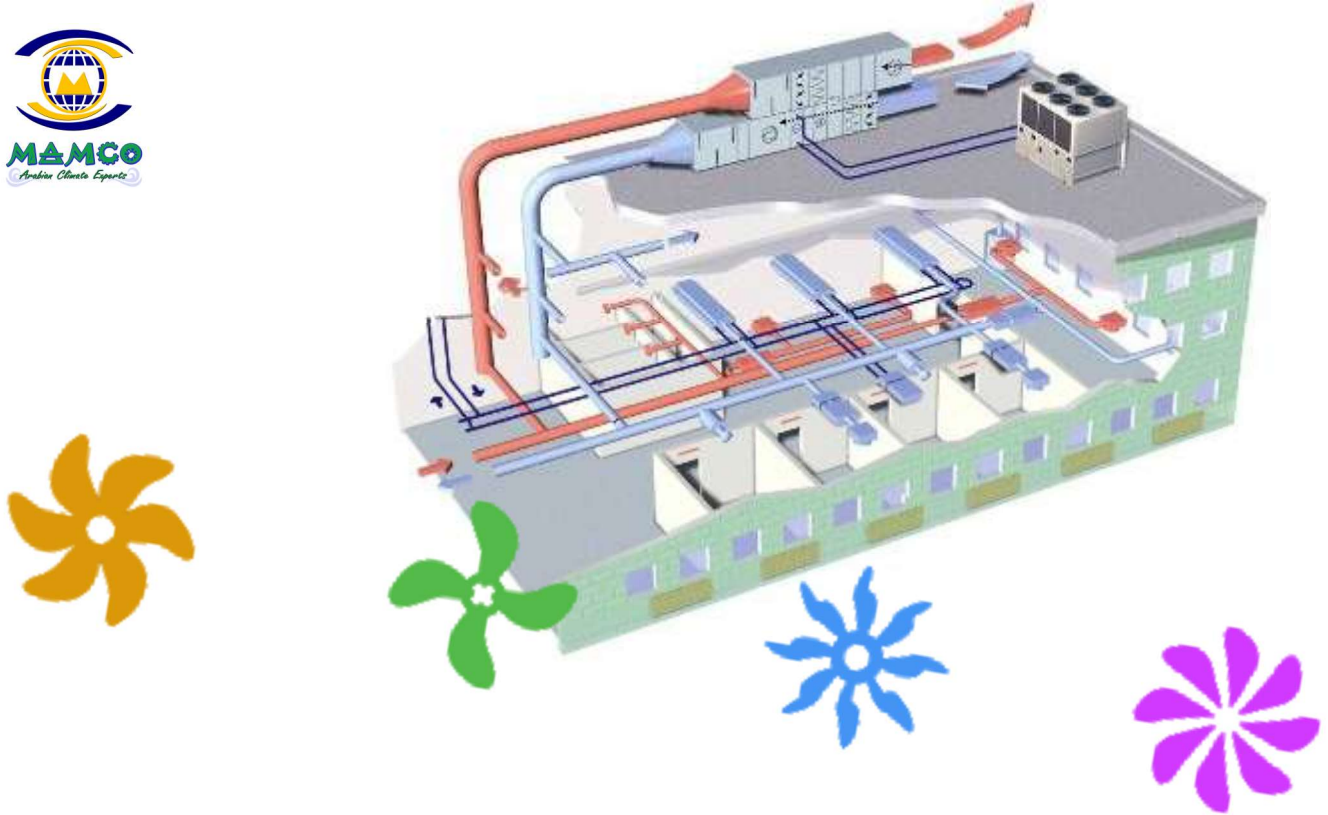

**We are trying to use advanced technology, science and engineering through our extinguished engineers and make benefit of their wide experience in providing effective service In HVAC**

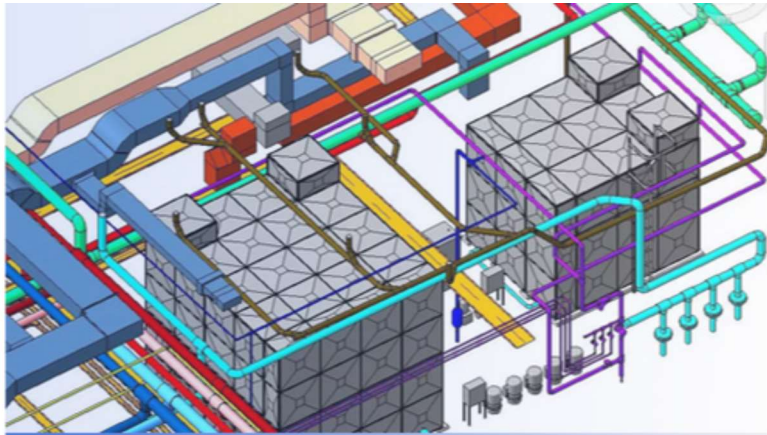

# Value Statement

Mohammed Ali Al Musallam General contracting is a company that will...

- Provide 100% customer satisfaction
- Be open and honest
- Work together as a team
- Change for the better of ourselves, customers, and industry
- Always think of new ways to promote growth and better serve our clientele

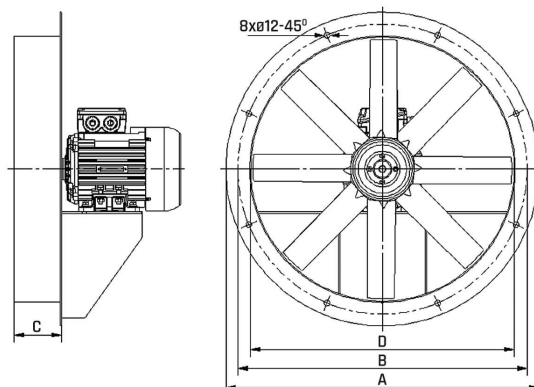

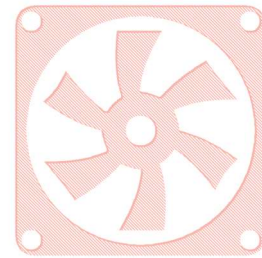

**Many ways of expressing the idea of an idea await your consideration**



**A systematic inquiry to describe, explain, predict and control the observed phenomenon in HVAC**



**When there is a call for action we are Attack the scope on the time frame**

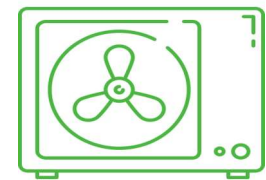

**Our goals can only be reached through a path of a plan, in which we must fervently believe, and upon which we must vigorously act, there is no other route to success**



**MAMCO**  
*Arabian Climate Experts*



# **O**RGANIZATION **C**HART



Organisational Chart

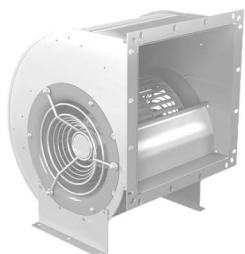
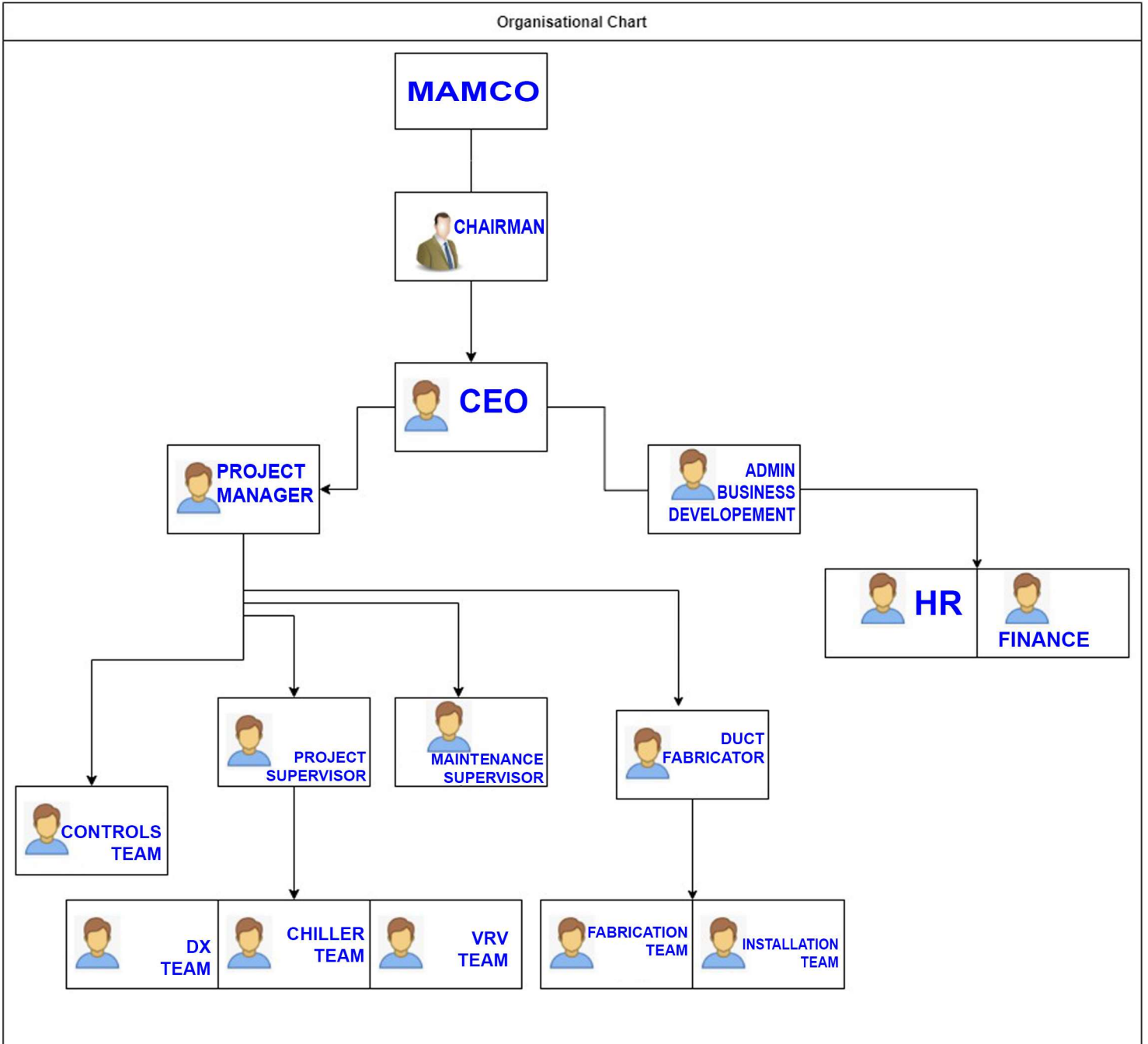



**MAMCO**  
*Arabian Climate Experts*



# **G**overnment **C**ertificates



تاريخ الإصدار: 2020/11/14  
الرقم المميز: 3004502381



الهيئة العامة للزكاة والدخل  
General Authority of Zakat & Tax



المدينة City	اسم الفرع Branch Name	رقم الرخصة License No.	رقم السجل التجاري CR No.
الأحساء	خياط محمد بن علي بن طاهر المسلم للخياطة النسائية		2051232441
الرياض	مؤسسة محمد بن علي بن طاهر المسلم التجارية		1010664687



كمخلف مسجل في ضريبة القيمة المضافة، لا يجوز لك تحصيل ضريبة القيمة المضافة من عملائك قبل تاريخ  
نفاذ التسجيل بالضريبة. في حال تبين غير ذلك، ستقوم الهيئة العامة للزكاة والدخل بتنفيذ الغرامات المستحقة.

هذه الوثيقة مرسلة من النظام الآلي ولا تحتاج إلى توقيع  
- الهيئة العامة للزكاة والدخل -









رقم الشهادة: ١٠٤١٠٨٣٥٠٤  
التاريخ: ١٤٤٣/٠٣/٢٦ هـ  
الرقم المميز: ٣٠٠٤٥٠٢٣٨١



الهيئة العامة للزكاة والدخل  
General Authority of Zakat & Tax

المملكة العربية السعودية  
الهيئة العامة للزكاة والدخل  
General Authority of Zakat & Tax

قائمة فروع المكلف مكتب محمد علي المسلم للخدمات العامة  
رخصة رقم ٤٢٧/٠١٠٧٩

رقم السجل	الرخصة	إسم الفرع	المدينة
٢٠٥١٠٥٤٥١٧	٤٢٩/٠٢٦٧٤	تابع السجل التجاري الرئيسي	الخبر
٢٠٥١٠٣٤١٩٠	٤٢٩/٠٠٤١٥	مؤسسة محمد علي المسلم للمقاولات العامة	الخبر
٢٠٥١٠٥٥٧١١	٤٣٥/٠٠٦٨٧	تابع سجل المقاولات العامة	الخبر
٢٠٥١٢٣١٩٢٧		مؤسسة محمد علي المسلم التجارية	الأحساء
٢٠٥١٢٣٢٤٤١		خياط محمد بن علي بن طاهر المسلم للخياطة النسائية	الأحساء
١٠١٠٦٦٤٦٨٧		مؤسسة محمد بن علي بن طاهر المسلم التجارية	الرياض
٢٠٥١٢٣٢٠١٦	٤٢٠٣٤٢٣٢٦٣٢	مؤسسة اصول الخليج التجارية	الخبر
٢٠٣١١٠٦١٣٣		بقالة شموع الزهراء للمواد الغذائية	الأحساء
٢٠٥١٢٣٦٣٢٤		مؤسسة محمد علي المسلم التجارية	الأحساء
٢٠٥١٢٣٦٨٥٠		مؤسسة ماما موضة للتجارة	الأحساء
٢٠٥١٢٣٧١٠٥		مؤسسة محمد علي المسلم التجارية	الأحساء



الختم الرسمي



رقم الشهادة : ١٠٤١٨٣٥٠٤  
التاريخ : ١٤٤٣/٠٣/٢٦ هـ  
الرقم المميز : ٣٠٠٤٥٠٢٣٨١



الهيئة العامة للزكاة والدخل  
General Authority of Zakat & Tax

المملكة العربية السعودية  
الهيئة العامة للزكاة والدخل  
General Authority of Zakat & Tax

## شهادة CERTIFICATE

تشهد الهيئة العامة للزكاة والدخل بأن المكلف / مكتب محمد علي المسلم للخدمات العامة  
سجل مدني رقم ١٠١١٨٣٩٤٢ وسجل تجاري رقم ٢٠٥١٣٣٠٠٦ رخصة رقم ٤٢٧/١٠٧٩  
قدم إقراره عن الفترة المنتهية في ١٤٤٢/٠٦/٣٠هـ

وقد منح هذه الشهادة لتمكينه من إنهاء جميع معاملاته بما في ذلك صرف مستحقاته  
النهائية عن العقود.

يسري مفعول هذه الشهادة حتى تاريخ ١٤٤٣/١٠/٢٩ هـ الموافق ٢٠٢٢/٠٥/٣٠ م.  
(التاسع و العشرون من شوال ألف و أربعمئة و ثلاثة و أربعون هجري)

الفروع ( ١١ ) في النموذج المرفق



الختم الرسمي



## Membership Certificate - شهادة الاشتراك



The Unified Number: 7012822719

الرقم الموحد للمنشأة: 7012822719

Classification: Third

الدرجة: الثالثة

Date of Issue: 01/11/2021

تاريخ الاصدار: 26/3/1443

Asharqia Chamber Certifies that:

تشهد الغرفة التجارية الصناعية بالمنطقة الشرقية بأن:

MOHAMMED ALI AL-MUSALLAM GEN.CONT.EST.

مؤسسة محمد علي المسلم للمقاولات العامة

Membership No: 133274

رقم الاشتراك: 133274

Registered with Chamber since: 07/02/2010 and

مشتركة في الغرفة منذ: 23/02/1431

the certificate expires on: 10/09/2022

وينتهي سريان هذه الشهادة في: 14/02/1444

,79113, الخير, 31952

,79113, الخير, 31952



يمكنك التحقق من صحة هذه الشهادة  
<https://www.chamber.org.sa/VerifyCert>





Saudi Aramco E-Reference No. 0005462

## Registration Approval Letter

October 04, 2022

**Attention : MOHAMMED BIN ALI AL MUSALLAM GENERAL CONTRACTING EST.**

**CR Number : 2051034190**

**Supplier Type: Service Provider Only**

**Country : Saudi Arabia**

We are pleased to inform you that MOHAMMED BIN ALI AL MUSALLAM GENERAL CONTRACTING EST. is now registered in the Saudi Aramco Supplier Management System under Vendor Code No. 10109112, provided your company continues to meet all relevant Saudi Arabian and Saudi Aramco standards.

This registration, however, should not be construed as a commitment by Saudi Aramco to procure from you. Being registered as a supplier only grants your company the opportunity, along with other registered sources, to respond to requests for submitting proposals in accordance with Saudi Aramco's established policies and procedures. All procurement instruments including but not limited to service contracts, purchase agreements, or purchase orders will be issued based on the name and address included in your commercial registration (CR), as stated in your Supplier Registration.

Saudi Aramco wishes to remind you that being recognized as a supplier carries with it serious obligations and responsibilities to act in a legal and ethical manner. We wish to remind you of the Saudi Aramco Supplier Code of Conduct (SCOC) which you acknowledged. Failure to abide by the principles set forth in the SCOC can result in adverse actions being taken by Saudi Aramco against you including suspension of you as a supplier. Saudi Aramco also expects each of its suppliers to satisfy each of the requirements of any procurement instrument which might be placed and to act responsibly and reliably as a supply chain supplier.

Material Suppliers should apply for Saudi Aramco Supplier Portal access by forwarding a request to [portal-registration@aramco.com](mailto:portal-registration@aramco.com). The Supplier Portal is the main electronic business tool used between Saudi Aramco and its suppliers and serves to improve the flow and accuracy of key supply chain information.

For further information or assistance please contact the Saudi Aramco Supplier Help Desk by forwarding a request to [SupplierHelpDesk@aramco.com](mailto:SupplierHelpDesk@aramco.com) or via the unified call center 800-116-1168 for In-Kingdom suppliers or +966 (11) 290-8950 for Out-of-Kingdom suppliers.

Moamar Khazal Al Usaimi, Supervisor  
**Supplier Registration Unit**  
**Supplier Relationship Management Div**

It is the responsibility of the supplier to update Saudi Aramco Supplier Registration Profile through Ariba for the following:

1. Change of Name / Commercial Registration Number / Address / Owner(s)
2. Any change of the supplier location
3. Discontinue supply of approved commodities (9COMs and 9CATS)

This is an electronically generated letter by Saudi Aramco. To verify Supplier approval status, please contact Supplier Help Desk at [supplierhelpdesk@aramco.com](mailto:supplierhelpdesk@aramco.com)



**MAMCO**  
*Arabian Climate Experts*



# Bank Details





## **The Saudi National Bank**

**Account Name :  
Mohammed Ali Al-Musallam  
General Contracting EST.**

**Account No :  
01400003435108**

**IBAN No :  
Sa7810000001400003435108**



# OUR MAJOR CLIENTS



# ARKEMA



# DRESSER-RAND®

A Siemens Business



**NOV**



**TRC**



**FLowsERVE**

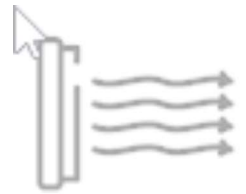

مسابك  
**MASABIK**



الأنصاري  
مقاولات عامة  
AL ANSARI  
GENERAL CONTRACTING



المجموعة الخليجية  
GULF GROUP



**MAMCO**  
*Arabian Climate Experts*



**OUR MAJOR  
SUPPLIERS**

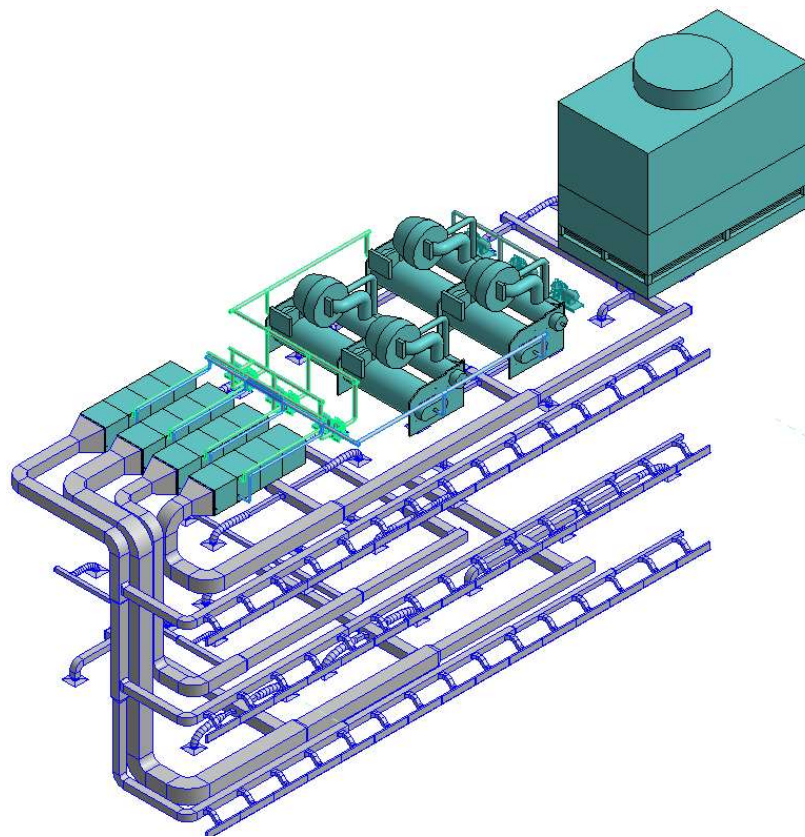

**Supplier relationship management (SRM) is the discipline of strategically planning for, and managing, all interactions with third party organizations that supply goods and services to an organization in order to maximize the value of those interactions.**



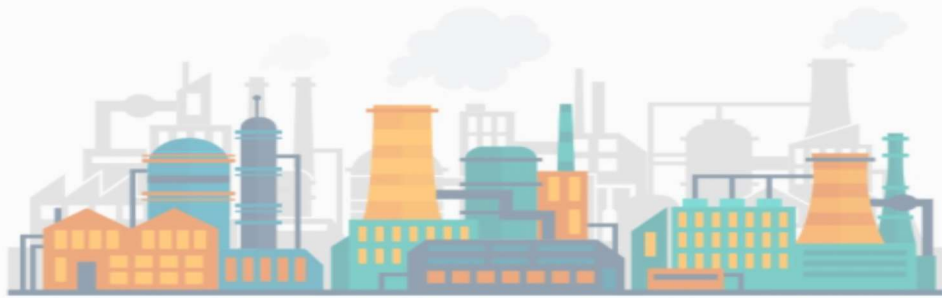

turn to the experts<sup>SM</sup>

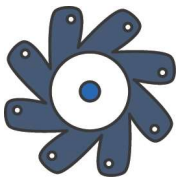

Petra Engineering Industries Co.

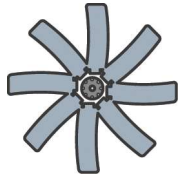

**TRANE<sup>®</sup>**



**GREE**  
air conditioner

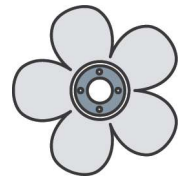

**COOK**





# Our Standards

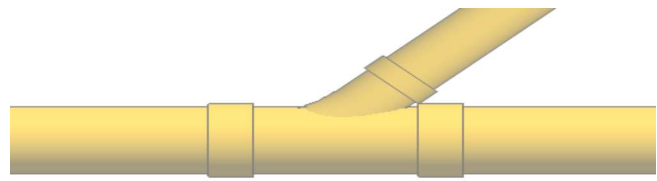

**The Sheet Metal and Air Conditioning Contractors' National Association (SMACNA) is an international trade association representing 1,834 member firms in 103 chapters throughout the United States.**

**Canada, Australia, and Brazil A leader in promoting quality and excellence in the sheet metal and air conditioning industry. SMACNA has Office in Chantilly, VA. which is outside of Washington, D.C., and on Capitol Hill.**



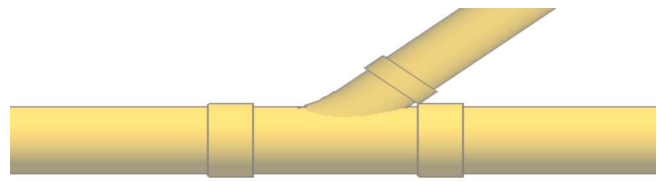

ASHRAE  
Associate  
Society  
Alliance

**ASHRAE, founded in 1894. is a global Society advancing human well-being through sustainable technology for the built environment.**

**The Society and its members focus on building systems, energy efficiency, indoor air quality. refrigeration and sustainability within the industry.**

**ASHRAE shapes tomorrow's built environment today.**

**ASHEAE was formed as the American Society of Heating, Refrigerating and Air-Conditioning Engineers by the merger in 1959 of American Society of Heating and Air-Conditioning Engineer<sup>5</sup> (ASHRAE) founded in 1894**

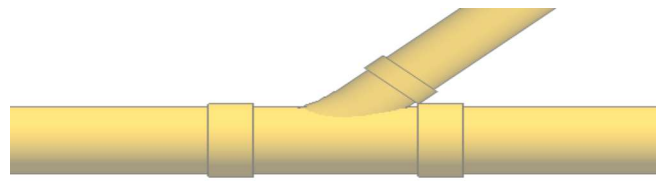

**The Air Movement and Control Association International, Inc. (AMCA) is a long-established American trade body that sets standards for heating, Ventilation and Air Conditioning (HVAC) equipment. It is best known for its ratings for fan balance and vibration, aerodynamic performance. air density, speed and efficiency.**

**AMCA was formed in 1955 from several earlier trade associations which could be traced back to the fan-testing requirements of the US Navy in 1923.**

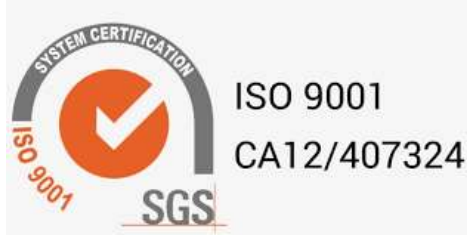
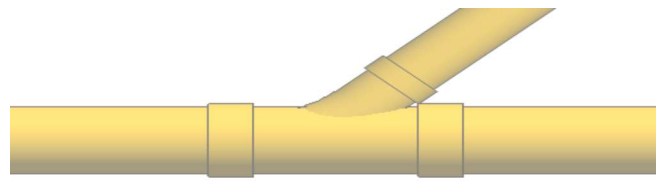

**The ISO 9000 family of quality management systems is a set of standards that helps organizations ensure they meet customer and other stakeholder needs within statutory and regulatory requirements related to a product or service**

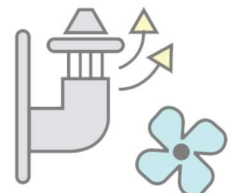





**MAMCO**  
*Arabian Climate Experts*



**Our Services**



Projects



Maintenance



DESIGN



Controls



Duct Fabrication





**MAMCO**  
*Arabian Climate Experts*

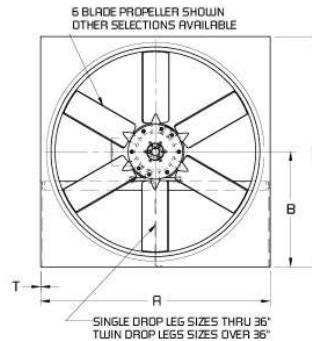
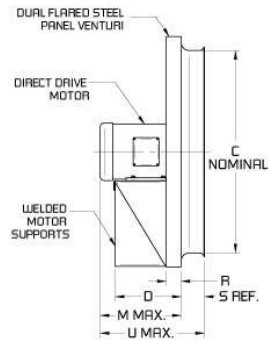

**DESIGN**

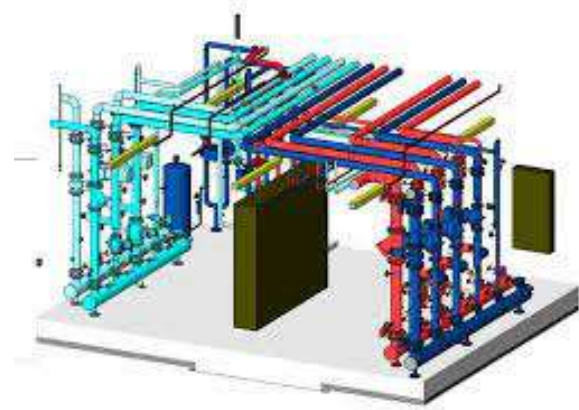

## **IFC Drawing :**

**It is the short form of “ISSUED FOR CONSTRUCTION”.**

**This is the drawing is given by the consultant for construction purposes as well as to prepare the shop drawings by the contractor.**

## **Shop Drawing :**

**A shop drawing making in a Actual Scale which is produced by consultants (OR) contractor.**

## **As built drawings:**

**An as-built drawing is defined as a drawing created and submitted by a contractor after completing the project which is show all the minor and major modifications made by the contractor as per the site condition.**

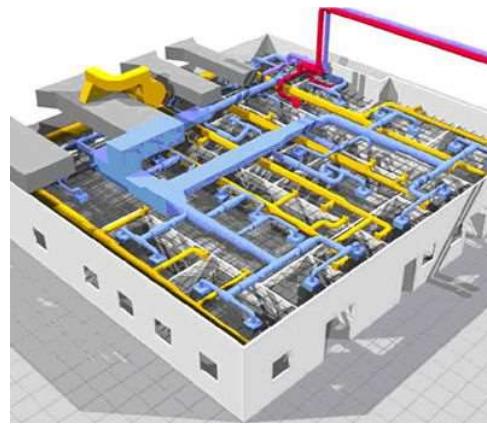

# Heating and Cooling Load Calculations :

Heating and cooling load calculations are carried out to estimate the required capacity of heating and cooling systems, which can maintain the required temperature conditions in the conditioned space .

## BOQ :

It is the short form of "BILL OF QUANTITY" which is making from the IFC drawings by a proper take off. it will be reflected on the quotation as mention the line items to specify to obtain the value of the contract.

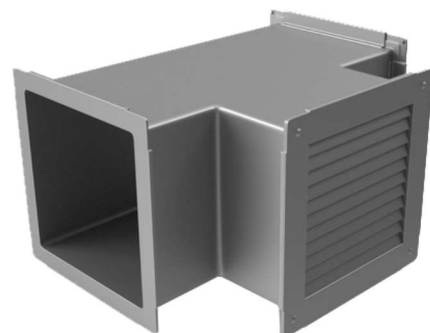

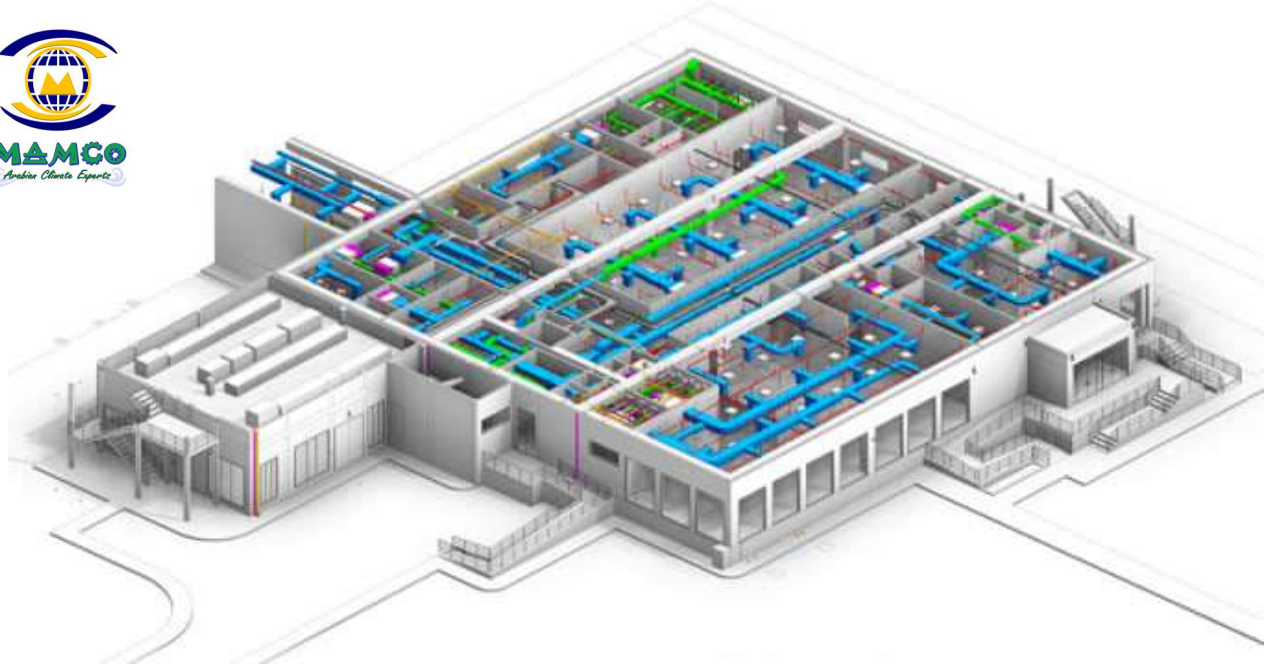

## **Estimate:**

**An HVAC estimator analyzes the scope of a proposed heating, Ventilation and air conditioning project to create a detailed estimate of the project's cost. As an HVAC estimator, you consider the cost of labor and materials and describe what is needed for our client's consideration.**





**MAMCO**  
*Arabian Climate Experts*



**P**roject

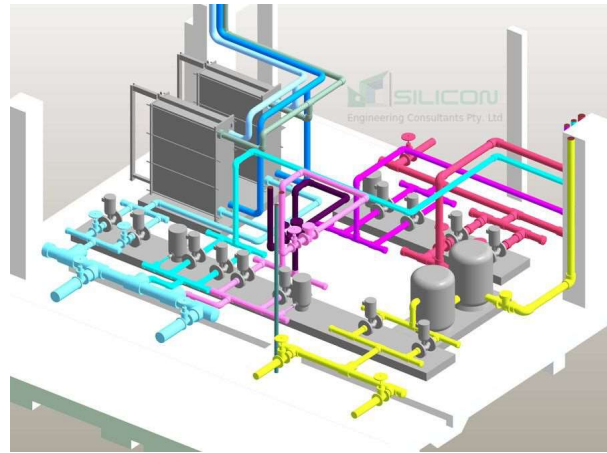

## **DX :**

**DX stands for direct expansion cooling. In DX cooling equipment, a refrigerant coil is placed directly in the supply air stream. As the refrigerant evaporates and expands, it removes energy, lowering the temperature of the supply air stream.**

## **VRF :**

**VRV stands for "Variable Refrigerant Volume," while VRF stands for "Variable Refrigerant Flow". ... VRV is term copyrighted by Daikin, one of the true industry leaders in HVAC equipment and technology.**



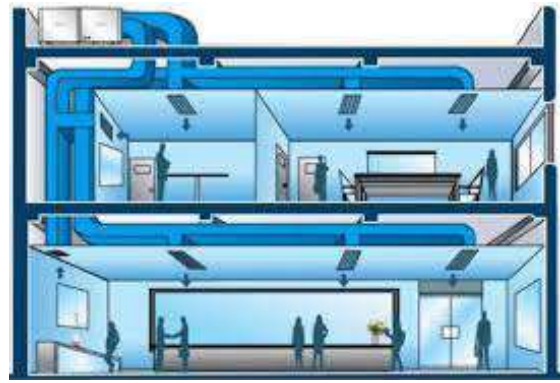

## **CHILLER :**

**A chiller is a machine that removes heat from a liquid coolant via a vapor-compression, adsorption refrigeration, or absorption refrigeration cycles. This liquid can then be circulated through a heat exchanger to cool equipment, or another process stream (such as air or process water).**

## **COLD STORAGE :**

**The term Cold room, as generic as the name may sound, refers to a specially built room, chamber or an enclosure that is well-insulated or lagged so as to prevent direct thermal flow out of the room.**

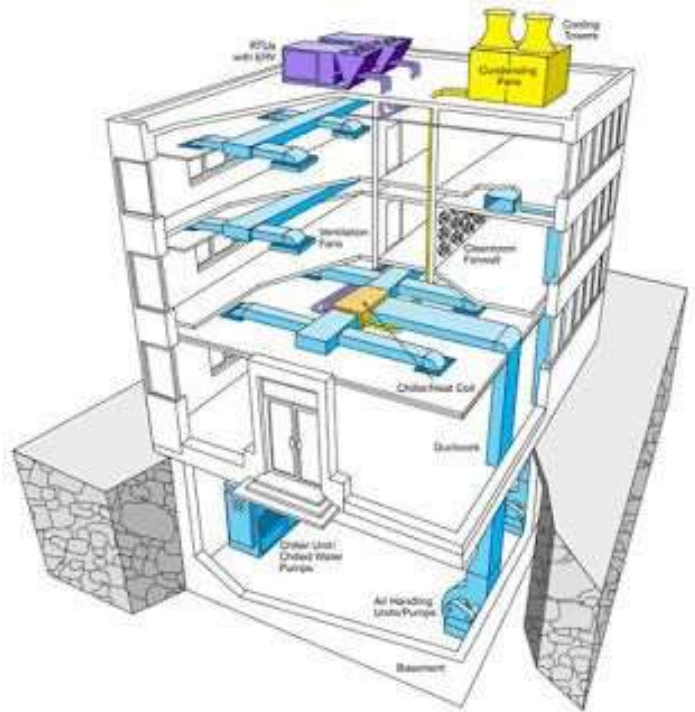

## PRECISION :

Precision cooling is an air conditioning or cooling technique that is specifically designed for use in IT equipment and environments and is implemented in devices that directly cool electronic and IT equipment.

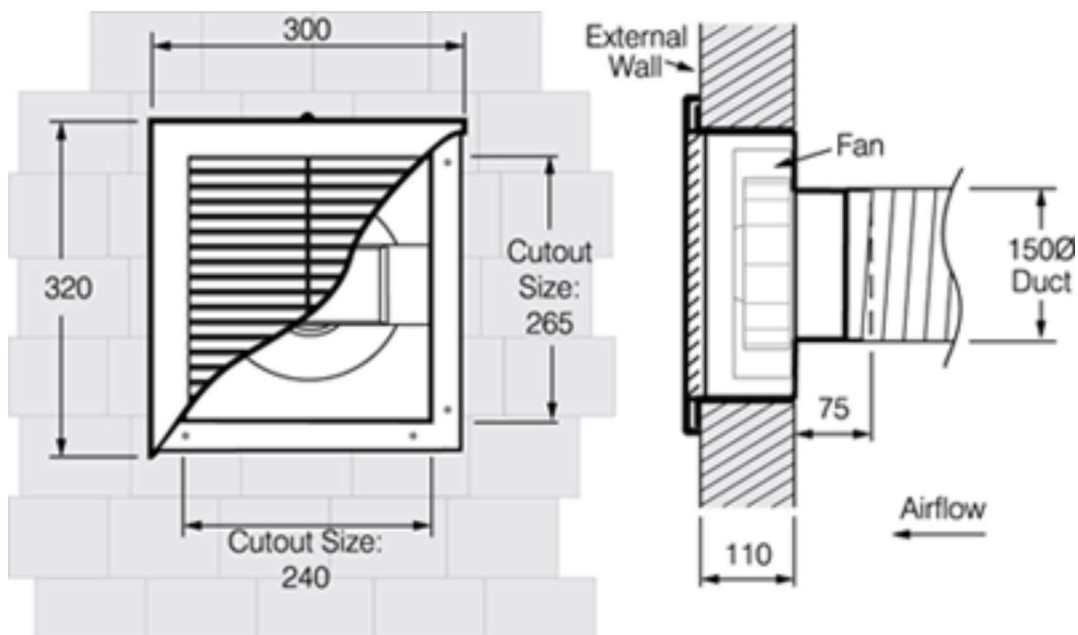



**MAMCO**  
*Arabian Climate Experts*



**Maintenance**



## **One Time Service :**

**Making a full service for your air conditioning with good efficiency on call basics.equipment.**

## **Annual Maintenance :**

**We are taking one-year preventive maintenance in this four times we do full service with chemicals for indoor and outdoor then you call us “N” no of calls for service we will in which you’re going to pay for one year only all service will be zero cost.**

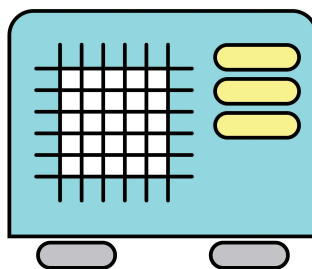



**MAMCO**  
*Arabian Climate Experts*



**Duct Fabrication**

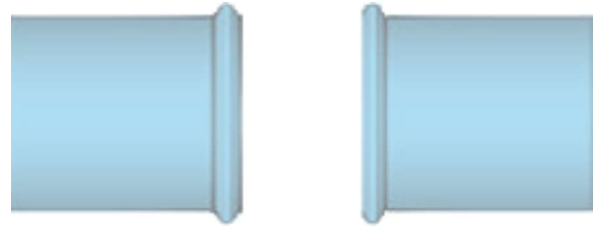

## Spiral Duct :

A spiral or round duct is typically made from galvanized steel and occasionally aluminium. If not from sheet metal, spiral ducts can be fiberglass board or a flexible plastic and wire composite.

Spiral ducts are being used more frequently and can be any length, but the most common cut is 20 feet in order to fit in a standard truck. The ducts can be connected using slip joints or flange-to-flange connection methods, depending on additional performance requirements.

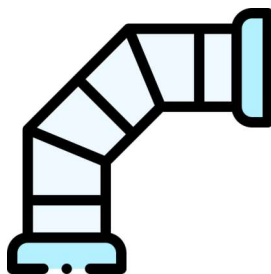

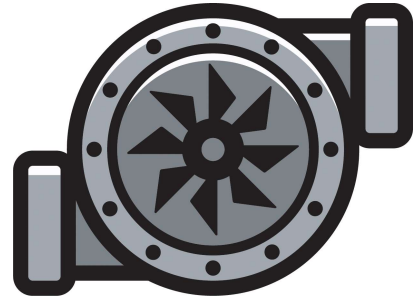

## Square Duct :

A Square duct has approximately 32 percent more sheet metal in it (likely galvanized steel), costing slightly more with insulation, support, and labor. They can also be made of fiberglass board. However, the overall capital cost is worthwhile because rectangular ducts.

## Double Skin :

Ducts built with double layer is called double skin.

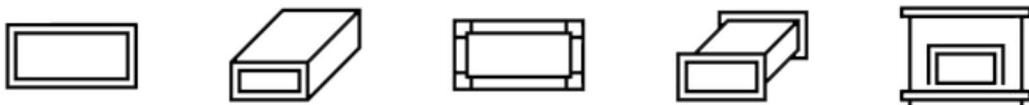

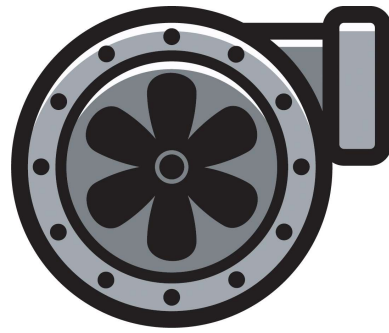

## Round Duct :

Round duct, which has lower and better pressure drop characteristics that reduce fan speed, is also more rigid than rectangular duct. This reduces the drum effect from duct vibration in comparison to a rectangular duct, which can transmit excessive noise if not properly supported.







**MAMCO**  
*Arabian Climate Experts*



**Controls**





**MAMCO**  
*Arabian Climate Experts*



**O**ur some  
**A**ccomplished  
**P**rojects



## CLIENT

## Main Contractor

## Project

أرامكو السعودية  
Saudi Aramco



EQUIPMENT BLDG.  
HOT TAP & SHOP  
@ ARAMCO DHAHRAN  
KHURSANIYAH - CONST.  
OME BUILDING @ARAMCO



JUBAIL INDUSTRIAL  
COLLEGE @ JUBAIL

 **Hilton**  
Garden Inn™



HILTON GARDEN INN  
@ JUBAIL

 **C.A.T.**  
GROUP



C.A.T ADMIN BUILDING  
@ KHOBAR



## CLIENT

## Main Contractor

## Project

ارامكو السعودية  
Saudi Aramco



WAREHOUSE @  
BAQAIQ & RASTHANURA



DAMMAM & QATIF  
HEAD OFFICE @ DAMMAM



AK FARM HOUSE  
@ SALASIL



KEMPINSKI  
AL OTHMAN HOTEL  
@ KHOBAR



**MAMCO**  
*Arabian Climate Experts*



**Our Gallery**



**MOHAMMED ALI AL MUSALLAM GEN. CON. CO.,**

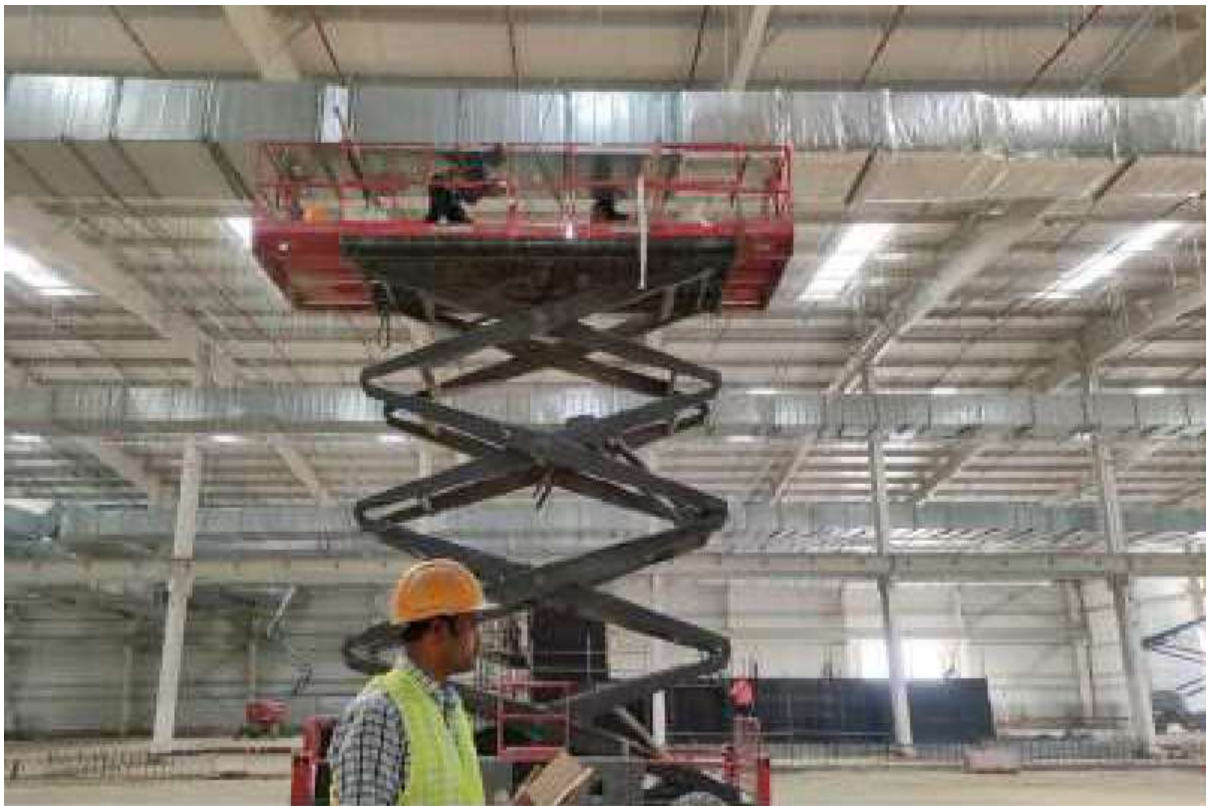



# MOHAMMED ALI AL MUSALLAM GEN. CON. CO.,







# MOHAMMED ALI AL MUSALLAM GEN. CON. CO.,





**MOHAMMED ALI AL MUSALLAM GEN. CON. CO.,**





**MOHAMMED ALI AL MUSALLAM GEN. CON. CO.,**





**MOHAMMED ALI AL MUSALLAM GEN. CON. CO.,**

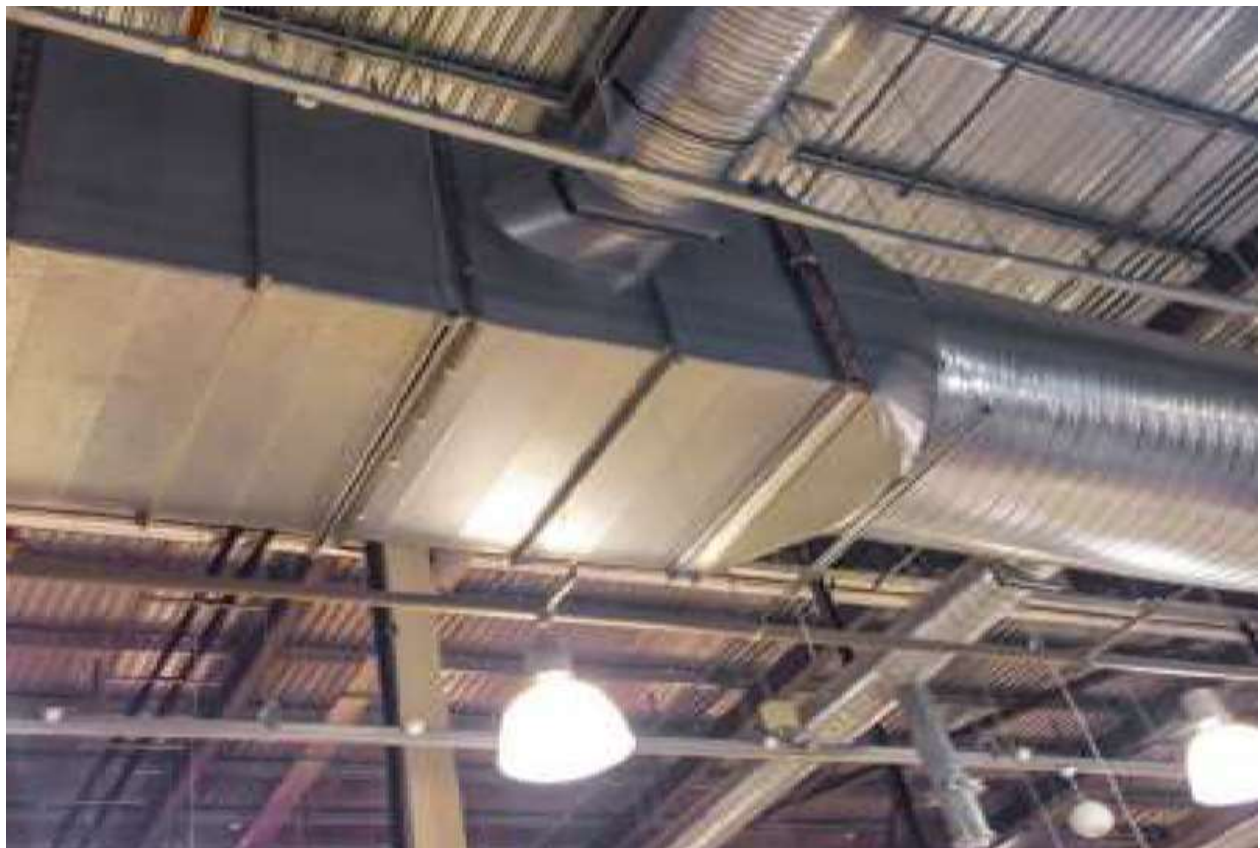



**MOHAMMED ALI AL MUSALLAM GEN. CON. CO.,**





**MOHAMMED ALI AL MUSALLAM GEN. CON. CO.,**





**MOHAMMED ALI AL MUSALLAM GEN. CON. CO.,**





**MOHAMMED ALI AL MUSALLAM GEN. CON. CO.,**







**MOHAMMED ALI AL MUSALLAM GEN. CON. CO.,**





**MOHAMMED ALI AL MUSALLAM GEN. CON. CO.,**





# MOHAMMED ALI AL MUSALLAM GEN. CON. CO.,





# MOHAMMED ALI AL MUSALLAM GEN. CON. CO.,





# MOHAMMED ALI AL MUSALLAM GEN. CON. CO.,





# MOHAMMED ALI AL MUSALLAM GEN. CON. CO.,





# MOHAMMED ALI AL MUSALLAM GEN. CON. CO.,





**MAMCO**  
*Arabian Climate Experts*

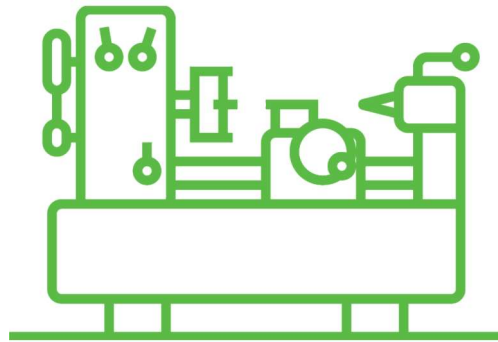

# **E**quipment**ment** **&** **M**achinery**ery**



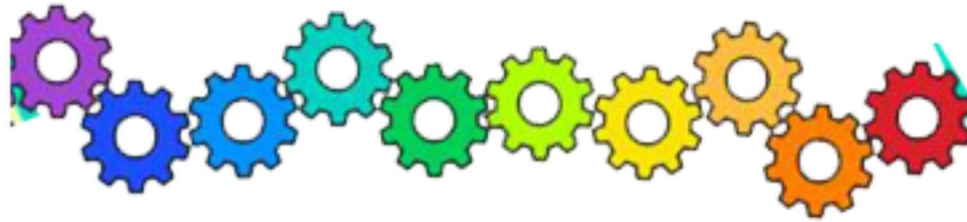

**Most advanced technology Machineries are contributing to our Company growth of scale. Machinery is reduced human effort and which gives more accuracy on our time frame.**

**Cutting Machine Bending Machine Tie Rod Machine Lock former Machine C & S Cleat Machine Roller Machine Grove Machine**



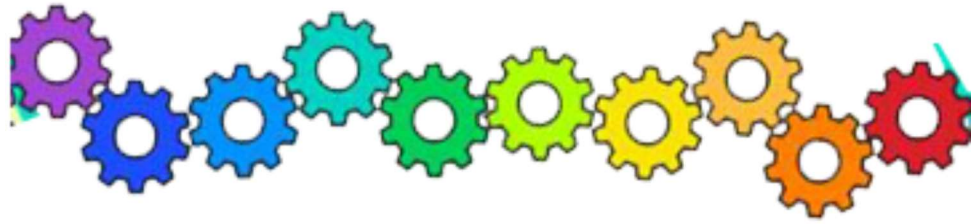

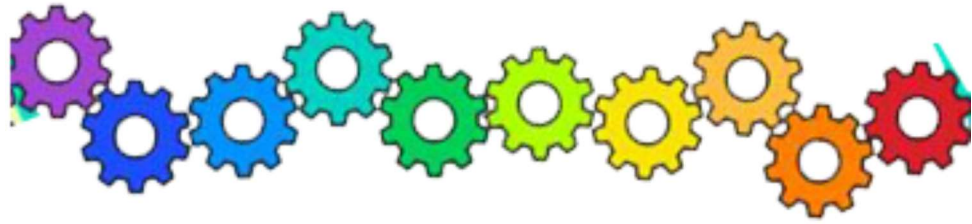

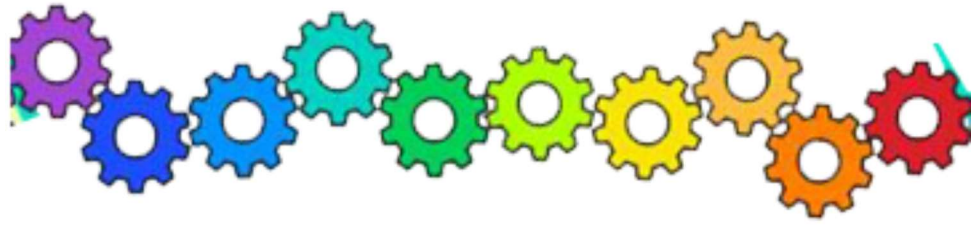



**MAMCO**  
*Arabian Climate Experts*



**L**ocation  
&  
**C**ontact

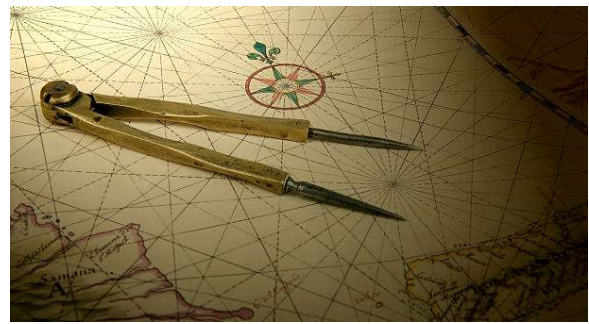

# Address - OFFICE

+966 500 810 730

info@mamcoair.com

King Saud Street - Cross 1/2  
Al-Khobar 31952, KSA

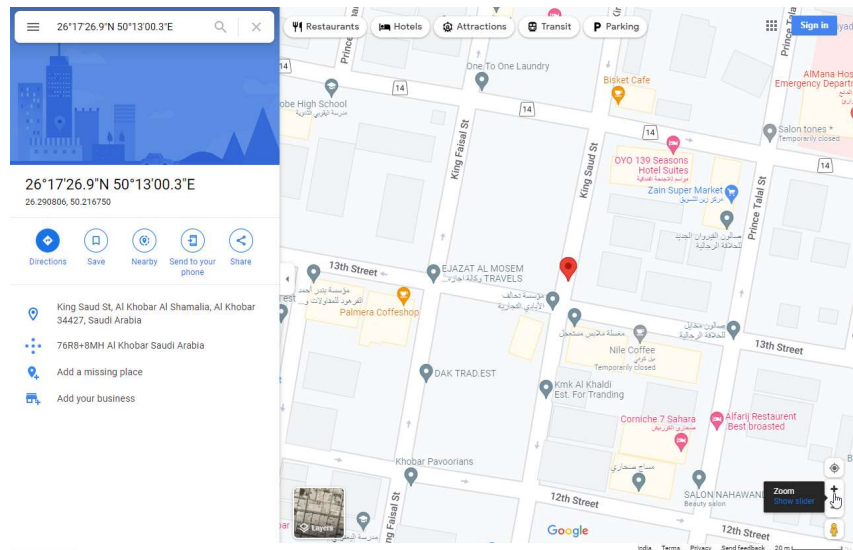

KEEP IN TOUCH  
-.-.-.-.-/..-./-.-.-.-.-

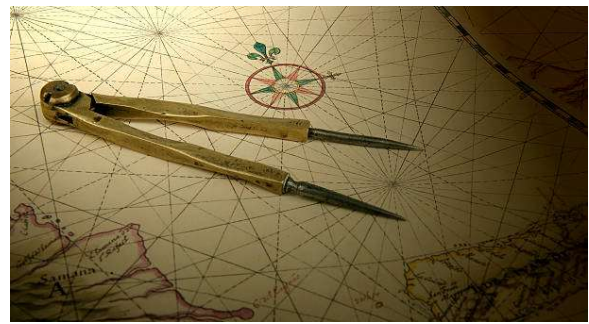

# Address - WORKSHOP

Sinayiat Alfawaziya

Al Khobar 34627

26.244765, 50.212866

+966 500 810 730

+966 0566854441

+966 564 300 065



TO RAHRAIN

← TO DAMMAM



→ TAKE 1<sup>ST</sup> LEFT



KEEP IN TOUCH  
- . . . . / . . . . / - - - - . . . . .

MAMCO  
Workshop





[www.mamcoair.com](http://www.mamcoair.com)  
[info@mamcoair.com](mailto:info@mamcoair.com)  
[service@mamcoair.com](mailto:service@mamcoair.com)  
[controls@mamcoair.com](mailto:controls@mamcoair.com)



KEEP IN TOUCH  
-.-.-.-.-/..-./-.-.-.-.-







      
**KEEP IN TOUCH**  
..... / ..... / .....

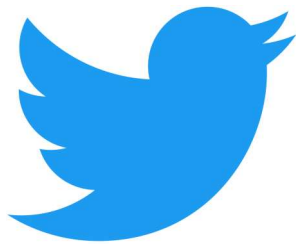



**T** **h** **a** **n** **k**  
**Y** **O** **U**



**MAMCO**  
*Arabian Climate Experts*

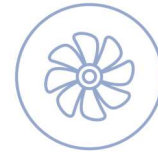
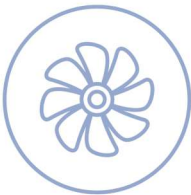

**PRE QUALIFICATION**